

NT1 Type 400 Standalone

Part Number 1212016L1-20

Document Number 61212016L1-20A

September 1999





901 Explorer Boulevard
P.O. Box 140000
Huntsville, AL 35814-4000
Phone: (256) 963-8000

© 1999 ADTRAN, Inc.
All rights reserved.
Printed in USA.

This device complies with Part 15 of the FCC rules. Operation is subject to the following two conditions: (1) This device may not cause harmful interference, and (2) this device must accept any interference received, including interference that may cause undesired operation.



Changes or modifications to this unit not expressly approved by the party responsible for compliance could void the user's authority to operate the equipment.

Canadian Standards Association

This device must be powered by a CSA approved power supply or a power supply meeting the requirements of CS03, Part I Section 1.4.2.

Warranties

ADTRAN will repair or replace this product within five years from the date of shipment if it does not meet its published specifications or fails while in service. For detailed warranty, repair, and return information, refer to the ADTRAN Equipment Warranty and Repair and Return Policy Procedure. Return Material Authorization (RMA) is required prior to returning equipment to ADTRAN. (See inside back cover for phone number and address to use.)

FCC regulations require that the following information be provided in this manual:

1. This equipment complies with Part 68 of the FCC rules. On the bottom of the equipment housing is a label that shows the FCC registration number and Ringer Equivalence Number (REN) for this equipment. If requested, provide this information to the telephone company.
2. If this equipment causes harm to the telephone network, the telephone company may temporarily discontinue service. If possible, advance notification is given; otherwise, notification is given as soon as possible. The telephone company will advise the customer of the right to file a complaint with the FCC.
3. The telephone company may make changes in its facilities, equipment, operations, or procedures that could affect the proper operation of this equipment; advance notification and the opportunity to maintain uninterrupted service is given.
4. If experiencing difficulty with this equipment, please contact ADTRAN for repair and warranty information. The telephone company may require this equipment to be disconnected from the network until the problem is corrected, or it is certain the equipment is not malfunctioning.
5. This unit contains no user-serviceable parts.
6. An FCC compliant telephone cord with a modular plug is provided with this equipment. In addition, an FCC compliant cable appropriate for the dial backup option ordered is provided with this equipment. This equipment is designed to be connected to the telephone network or premises wiring using an FCC compatible modular jack, which is Part 68 compliant.
7. The following information may be required when applying to the local telephone company for leased line facilities.

Service Type	Digital Facility Interface Code	Service Order Code	Network Jacks
ISDN	02IS5	6.0N	RJ-49C

ADTRAN YEAR 2000 (Y2K) READINESS DISCLOSURE

ADTRAN has established a Year 2000 program to ensure that our products and operations will correctly function in the new millennium. ADTRAN warrants that all products meet Year 2000 specifications regardless of model or revision. Information about ADTRAN's Year 2000 compliance program is available at the following:

Web Site	www.adtran.com
Product Matrix	www.adtran.com/Y2Kfax.html
Faxback Document Line	(256) 963-8200 <i>Y2K plans and product certifications are listed in the matrix</i>
Y2K Project Line	(256) 963-2200
E-mail	year2000@adtran.com

CUSTOMER INSTRUCTIONS

1. The mounting of the registered unit in the final assembly must be made so that the registered unit is isolated from exposure to any hazardous voltages within the assembly. Adequate separation and restraint of cables and cords must be provided.
2. The circuitry from the registered unit to the telephone line must be provided in wiring that carries no other circuitry unless specifically allowed by the rules (such as PC and PR leads). PC board traces carrying tip and ring leads shall have sufficient spacing to avoid surge breakdown.
3. A modular plug or jack shall be provided which complies with Part 68, Subpart F requirements for dimensions, tolerances metallic plating.

CANADIAN EMISSIONS REQUIREMENTS

This digital apparatus does not exceed the Class B limits for radio noise emissions from digital apparatus as set out in the interference-causing equipment standard entitled "Digital Apparatus," ICES-003 of the Department of Communications.

Cet appareil numérique respecte les limites de bruits radioélectriques applicables aux appareils numériques de Class B prescrites dans la norme sur le matériel brouilleur: "Appareils Numériques," NMB-003 édictée par le ministre des Communications.

CANADIAN EQUIPMENT LIMITATIONS

Notice: The Canadian Industry and Science Canada label identifies certified equipment. This certification means that the equipment meets certain telecommunications network protective, operational, and safety requirements. The Department does not guarantee the equipment will operate to the user's satisfaction.

Before installing this equipment, ensure that it is permissible to be connected to the facilities of the local telecommunications company. The equipment must also be installed using an acceptable method of connection. In some cases, the company's inside wiring associated with a single-line individual service may be extended by means of a certified connector assembly (telephone extension cord). Compliance with the above conditions may not prevent degradation of service in some situations.

Repairs to certified equipment should be made by an authorized Canadian maintenance facility designated by the supplier. Any repairs or alterations made by the user to this equipment, or equipment malfunctions, may give the telecommunications company cause to request the user to disconnect the equipment.

Users should ensure for their own protection that the electrical ground connections of the power utility, telephone lines, and internal metallic water pipe system, if present, are connected together. This precaution may be particularly important in rural areas.



Users should not attempt to make such connections themselves, but should contact the appropriate electric inspection authority, or an electrician, as appropriate.

The Load Number (LN) assigned to each terminal device denotes the percentage of the total load to be connected to a telephone loop which is used by the device, to prevent overloading. The termination on a loop may consist of any combination of devices subject only to the requirement that the total of the Load Numbers of all devices does not exceed 100.

Table of Contents

Table of Contents	ix
List of Figuresxi
List of Tables	xiii
Chapter 1 About the NT1 Type 400.	1-1
Unit Overview	1-1
LED Indicators	1-1
Basic Rate Description	1-2
Passive Bus Description	1-2
Powering TEs from the NT1	1-3
Rear Panel	1-3
Chapter 2 Installation	2-1
Setting the Option Switches	2-1
Powering Up the NT1 Type 400 Standalone	2-2
Connecting the Terminal Equipment	2-3
Chapter 3 Troubleshooting	3-1
Maintenance	3-2
Remote Testing	3-2
Repair and Return	3-2
Appendix A NT1 Type 400 Circuit Pack	A-1
Appendix B S/T Bus Configurations	B-1
Appendix C Specifications	C-1
Index	Index-1

List of Figures

Figure 1-1. NT1 Type 400 Standalone Rear Panel	1-3
Figure 2-1. NT1 Type 400 Switch Option Locations	2-1
Figure A-1. NT1 T400 Circuit Pack Connector Pin Assignments	A-2
Figure B-1. Short Passive Bus Configuration	B-1
Figure B-2. Extended Passive Bus Configuration.	B-2

List of Tables

Table 1-1.	NT1 Type 400 Front Panel Indicators	1-2
Table 2-1.	NT1 Type 400 Switch Settings	2-2
Table 2-2.	NT1 Pin Assignments	2-3

UNIT OVERVIEW

The ADTRAN NT1 Type 400 provides a basic rate interface between the customer's ISDN Terminal Equipment (TE) and the ISDN Network. Two interfaces are provided for this purpose: connection to the ISDN network is made by the "U" interface and connection to the customer's ISDN TE is made by the S/T interface.

The NT1 Type 400 is available in two configurations:

- The NT1 Type 400 Standalone with an internal power supply, Part No. 1212016L1.
- The NT1 Type 400 Circuit Pack, Part No. 1212010.

The ADTRAN NT1 Type 400 Standalone consists of two parts, a metal housing containing the power supply, connectors, and the NT1 Type 400 Circuit Pack. The Circuit Pack can be removed from the housing by removing the plastic front panel and sliding the unit out of the housing. This allows access to the option switches which may be reset by the customer. The NT1 Type 400 Circuit Pack can also be purchased as a separate unit and mounted in a Type 400 NCTE rack, as indicated in Appendix A, *NT1 Type 400 Circuit Pack* on page A-1.

LED Indicators

Table 1-1 on page 1-2 describes the status of the LEDs located on the front panel of the NT1 Type 400. There are a **READY** and an **ERROR** indicator for each port of the NT1 Type 400.

Table 1-1. NT1 Type 400 Front Panel Indicators

LED	Color	Description
READY	Green	S/T and U interfaces ready to place call
ERROR	Red	S/T or U interface not ready
POWER	Green	Unit has power

If an **ERROR** indicator is illuminated, check the flash rate of the **READY** indicator to determine the source of the error. A faster 8 Hz flash rate (8 flashes per second) indicates a network problem. A slower 1 Hz rate (1 flash per second) indicates an S/T interface problem.

BASIC RATE DESCRIPTION

ISDN Basic Rate Service consists of two *B* channels at 64 kbps and a single *D* channel at 16 kbps. Basic Rate Service (2B+D Service) provides a total of 144 kbps to the customer for the transport of voice, circuit switched data, and packet switched data. Each *B* channel can be used for voice or data. The *D* channel carries the signaling information needed for call processing. The *D* channel can also carry packet switched data using the X.25 protocol.

PASSIVE BUS DESCRIPTION

The S/T interface used to connect to the customer TE has the ability to connect multiple devices. This arrangement is referred to as the *passive bus* and can be used to connect up to eight TEs to the same Basic Rate line, as described in Appendix B, *S/T Bus Configurations* on page B-1.

POWERING TEs FROM THE NT1

The ADTRAN NT1 Type 400 can be used to provide power for customer TEs. If the NT1 T400 circuit pack is used, a total of 12 watts is available. If the NT1 Type 400 Standalone unit is used, a total of seven watts is available. This power can be provided by Power Source 1 (PS1), which provides power over the transmit and receive wire pairs used by the S/T interface and requires no additional wire pairs; and by Power Source 2 (PS2), which provides power over an additional wire pair.

REAR PANEL

The NT1 Type 400 Standalone rear panel contains three RJ45 connectors, as illustrated in Figure 1-1. A single connector, labeled **NETWORK**, is used to connect to the ISDN network. The remaining two connectors, labeled **CUSTOMER 1** and **CUSTOMER 2**, are used to interface to the customer's TEs. These connectors are wired in parallel, and can be used to connect multiple TEs in a passive bus arrangement.

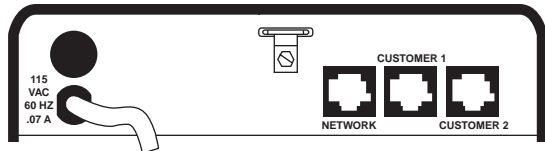

Figure 1-1. NT1 Type 400 Standalone Rear Panel

Chapter 2 Installation

After unpacking the unit, immediately inspect it for possible shipping damage. If damage is discovered, file a claim immediately with the carrier, then contact ADTRAN Customer and Product Service (CAPS) Department at the number listed in the back page of the manual.

SETTING THE OPTION SWITCHES

Remove the Circuit Pack from the NT1 Standalone housing by removing the plastic front panel and sliding the Circuit Pack out of the front of the unit. Figure 2-1 illustrates switch option locations; Table 2-1 on page 2-2 lists the function of each switch.

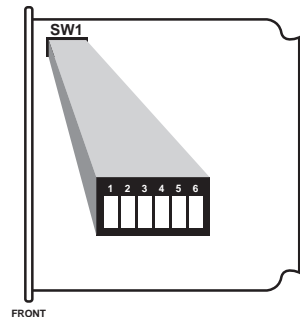

Figure 2-1. NT1 Type 400 Switch Option Locations

Table 2-1. NT1 Type 400 Switch Settings

Switch	Description	On	Off
6	50 Ω termination	50 Ω	None
5	50 Ω termination	50 Ω	None
4	100 Ω termination	100 Ω	None
3	100 Ω termination	100 Ω	None
2	Long or short passive bus	Long	Short
1	Future use	N/A	N/A

Refer to Appendix B, *S/T Bus Configurations* on page B-1 to determine what type of bus and termination apply to your installation to set the switches accordingly.

POWERING UP THE NT1 TYPE 400 STANDALONE

To power-up the NT1 Type 400 Standalone for the first time, perform the following procedures in order:

1. Plug the power cord into a grounded, 120 VAC, 60 Hz receptacle.
2. Verify that the **ERROR** indicators are illuminated. After about 15 seconds, the **READY** indicators should flash at a 1 Hz rate.
3. Should any of these indicators fail to operate as stated, see Chapter 3, *Troubleshooting* on page 3-1.

Table 2-2 on page 2-3 gives pin assignments for the unit.

Table 2-2. NT1 Pin Assignments

Pin	Network	Customers 1 & 2
1	No Connection	No Connection
2	No Connection	No Connection
3	No Connection	S/T Interface Receive
4	U-Interface	S/T Interface Transmit
5	U-Interface	S/T Interface Transmit
6	No Connection	S/T Interface Receive
7	No Connection	PS2 (Negative)
8	No Connection	PS2 (Positive)

CONNECTING THE TERMINAL EQUIPMENT

After successfully powering up the NT1 Type 400, the **ERROR** indicators should be on and the **READY** indicators should be flashing. Make sure that the TEs are properly terminated. Plug each TE into one of the S/T connectors at the rear of the unit.

After the TE powers up, the **ERROR** indicators should go out. There may be some delay between plugging in the TE and the **ERROR** indicators going out, depending on the specific TE in use. If the **ERROR** indicators fail to go out, see Chapter 3, *Troubleshooting* on page 3-1.

When the **ERROR** indicators go out, the **READY** indicators should illuminate. The TE will now be ready to place and receive calls. There may be a slight delay between the appearance of the **READY** indicators and the TE's ability to place and receive calls, depending on the specific TE in use. If the **READY** indicators fail to illuminate or if you are unable to place or receive calls, see Chapter 3, *Troubleshooting* on page 3-1.

If you encounter problems during installation, the following list shows possible symptoms and solutions. If these solutions fail to correct the problem, contact ADTRAN Technical Support at 888 4ADTRAN.

Problem	Possible Solution
POWER indicator is not illuminated.	<ul style="list-style-type: none"> • NT1 Type 400 needs replacement. • Insufficient power to the NT1 Type 400
ERROR indicators illuminated; READY indicators flash at a faster 8 Hz rate.	Network activation failure: <ul style="list-style-type: none"> • Wall jack wiring is incorrect: Check wall jack. • Problem with ISDN line: Contact telephone company
ERROR indicators illuminated; READY indicators flash at a slower 1Hz rate.	Local bus failure: <ul style="list-style-type: none"> • TE not connected: Connect TE. • TE not receiving power from NT1: Consult TE documentation. • TE not terminated properly: Correct termination. • TE ISDN parameters not configured properly: Reconfigure TE (SPIDs, LDNs, switch type, etc.).
READY indicators do not illuminate.	<ul style="list-style-type: none"> • Problem with ISDN network: Contact telephone company. • ISDN line not plugged into U jack: Plug ISDN line into U jack.
Unable to make or receive a call.	<ul style="list-style-type: none"> • TE is not compatible with ISDN network: Contact telephone company. • TE ISDN parameters not configured properly: Reconfigure TE (SPIDs, LDNs, switch type, etc.).

MAINTENANCE

The ADTRAN NT1 Type 400 requires no routine maintenance to operate. In case of equipment malfunction, refer to the sections, *Remote Testing* and *Repair and Return* below, and/or remove the unit and replace it with another unit optioned in an identical manner.

REMOTE TESTING

Network test features include a loopback test initiated at the central office. This test confirms network integrity to the NT1 Type 400.

REPAIR AND RETURN

Repairs should not be performed in the field. Repair services can be obtained by returning the unit to the ADTRAN Customer and Product Service (CAPS) Department at the address listed on the back page of this manual.

TYPE 400 NCTE RACK INSTALLATION

The ADTRAN NT1 Type 400 Circuit Pack, Part No. 1212010, can be purchased as a separate unit for installation in a Type 400 NCTE rack. This configuration provides a central location for the NT1 in a customer's wiring closet, and facilitates battery backup. Refer to ADTRAN's *Building a Battery Protected ISDN Phone System* for a complete description of the centrally located battery back-up system.

Figure A-1 on page A-2 shows the connector pin assignments of the ADTRAN NT1 Type 400 Circuit Pack. The Type 400 rack supplies -48V to the Circuit Pack. In addition, the Type 400 rack provides access to the necessary wire pairs for connection to the network and the customer's TE.

After ensuring that connections to the Type 400 rack are correct, and the circuit pack has been optioned properly, insert the circuit pack into the Type 400 rack by firmly pushing the circuit pack into one of the available slots. The circuit pack should slide in smoothly and snap into place.

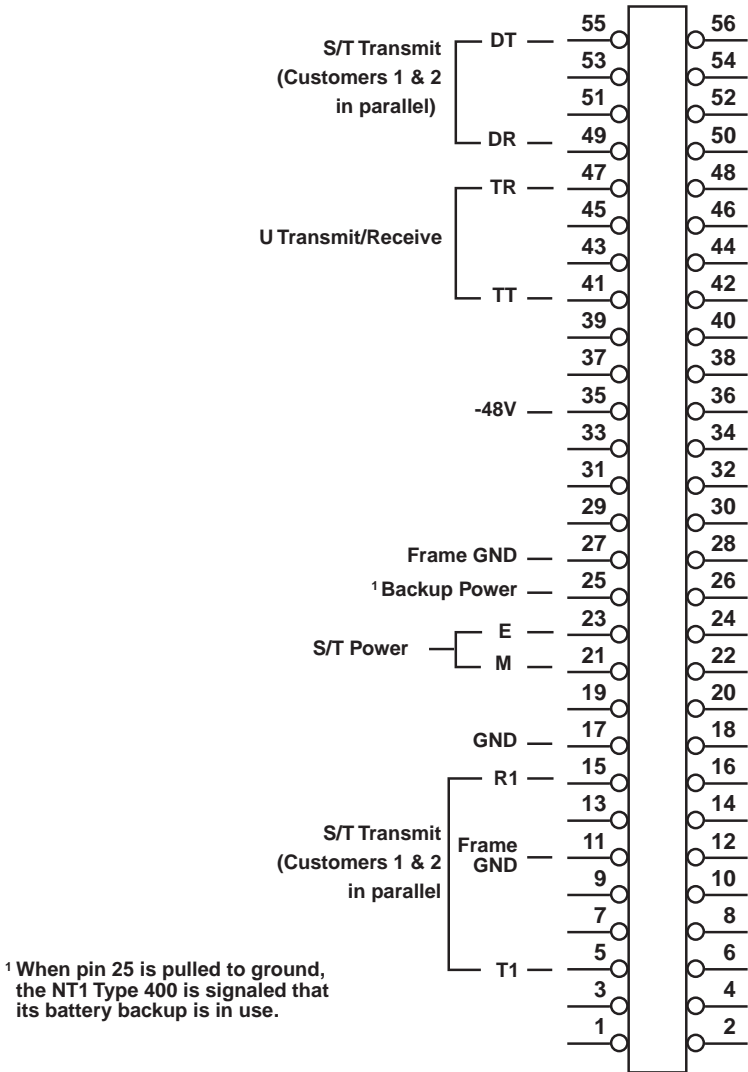

Figure A-1. NT1 T400 Circuit Pack Connector Pin Assignments

SHORT PASSIVE BUS

The short passive bus configuration allows the connection of up to eight TEs at any point on the bus. The bus length is limited to 600 feet, as illustrated in Figure B-1.

To select this bus configuration, set switch 1-2 to the Short position. The bus termination resistors (TRs) can be placed at any point along the bus. If the TEs have internal TRs that can be optioned, only one TE's TRs should be enabled. The TRs in the NT1 Type 400 are enabled by setting switches 1-3 and 1-4 to the **ON** position, and switches 1-5 and 1-6 to the **OFF** position. If the unterminated TEs are placed within 20 feet of the NT1, set switches 1-3 and 1-4 to the **OFF** position, and switches 1-5 and 1-6 to the **ON** position. The switch settings should always be maintained, unless an external 100 Ω resistor is being used. If an external TR is used, set switches 1-3 through 1-6 to the **OFF** position.

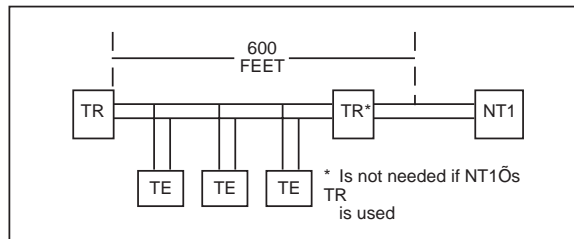

Figure B-1. Short Passive Bus Configuration

EXTENDED PASSIVE BUS

This bus configuration allows the connection of up to eight TEs at ranges up to 3000 feet from the NT1 Type 400, as illustrated in Figure B-2.

To select this mode, set switch 1-2 to the Long position. A TR must be centrally located to the TEs. The TRs in the NT1 Type 400 are enabled by setting switches 1-3 and 1-4 to the ON position, and switches 1-5 and 1-6 to the OFF position. These switch settings should always be maintained, unless an external 100 Ω resistor is being used. If an external TR is used, set switches 1-3 through 1-6 to the OFF position.

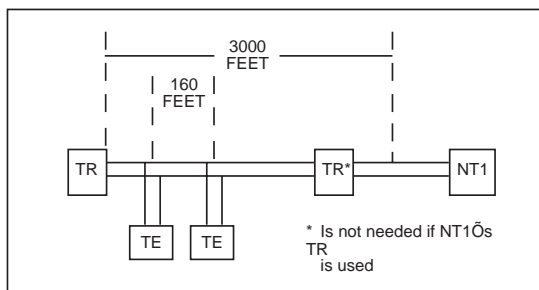

Figure B-2. Extended Passive Bus Configuration

Appendix C Specifications

LOOP INTERFACE:

Line:	2-Wire (TIP and RING)
Operating Mode:	Full-duplex
Data Rate:	160 kbps total; 144 kbps available to customer
Signal Format:	2B1Q
Output Amplitude:	2.5 V, zero-to-peak
Tx Source Impedance:	As per ANSI T1.601
Rx Source Impedance:	As per ANSI T1.601
Receiver Sensitivity:	As per ANSI T1.601

CUSTOMER INTERFACE:

Line:	4-Wire (Tx and Rx pair)
Operating Mode:	Full-duplex
Data Rate:	192 kbps total; 144 kbps available to customer
Signal Format:	Alternate Mark Inversion, 100% duty cycle
Output Amplitude:	.75 V, zero-to-peak
Tx Source Impedance:	As per ANSI T1.605
Rx Source Impedance:	As per ANSI T1.605
Receiver Sensitivity:	As per ANSI T1.605

MECHANICAL:

Size:	5.625" H x 6" D x 1.375" W
Weight:	10 oz.
Mounting:	Mounts in Type 400 equipment shelves

POWER:

NT1 Type 400 Standalone:	On-Card Dissipation 115 VAC Internal Power Supply 60 Hz, .07 amps Sources S/T Power to 7W
NT1 T400 Circuit Pack: (part no. 1212010)	-48 VDC 1.1 Watt Maximum On-Card Dissipation Sources S/T Power to 12W

ENVIRONMENTAL:

Temperature:	Operating 0 to +50 °C Storage -20 to +70 °C
Relative Humidity:	Up to 95%, noncondensing

Index

A

ADTRAN web site v

B

bus configurations B-1

C

circuit pack 1-1, A-1

pin assignments A-2

connecting terminal equipment
2-3

connectors 1-3

Customer and Product Service
3-2

customer instructions v

customer interface specifications
C-1

E

environmental specifications C-2

error indicators 2-3

extended passive bus B-2

F

FCC regulations iv

I

installation 2-1

ISDN Basic Rate Service 1-2

L

LED indicators 1-1, 1-2

loop interface specifications C-1

M

maintenance 3-2

mechanical specifications C-1

N

NCTE rack 1-1

NT1 1-3

NT1 Type 400

installation 2-1

overview 1-1

powering up 2-2

NT1 Type 400 Circuit Pack 1-1,
A-1

NT1 Type 400 Standalone 1-1
rear panel 1-3

O

option switches 2-1, 2-2

overview 1-1

P

passive bus 1-2

pin assignments 2-3
circuit pack A-2

power

available from circuit pack
1-3

available from standalone 1-3

power specifications C-2

powering TEs 1-3

powering up 2-2

problems 3-1

R

ready indicators 2-3

rear panel 1-3

remote testing 3-2

repair and return 3-2

S

S/T bus configurations B-1

short passive bus B-1
specifications C-1

switch settings 2-2

T

terminal equipment
 connecting 2-3
troubleshooting 3-1
Type 400 NCTE rack 1-1
 installation A-1

W

warranty iii
web site v

Y

Y2K v

Product Support Information

Presales Inquiries and Applications Support

Please contact your local distributor, ADTRAN Applications Engineering, or ADTRAN Sales:

Applications Engineering: (800) 615-1176

Sales: (800) 827-0807

Post-Sale Support

Please contact your local distributor first. If your local distributor cannot help, please contact ADTRAN Technical Support and have the unit serial number available.

Technical Support 888-4ADTRAN

Repair and Return

If ADTRAN Technical Support determines that a repair is needed, Technical Support will coordinate with the Customer and Product Service (CAPS) department to issue an RMA number. For information regarding equipment currently in house or possible fees associated with repair, contact CAPS directly at the following number:

CAPS Department: (256) 963-8722

Identify the RMA number clearly on the package, and return to the following address:

ADTRAN Customer and Product Service
6767 Old Madison Pike
Progress Center
Building #6, Suite 690
Huntsville, Alabama 35807

RMA # _____