

ADURAN

Nx56/64
(Second Generation)

Option Module PN 1202054L1
Plug-On Board PN 1202053L1

USER MANUAL



901 Explorer Boulevard
P.O. Box 070020
Huntsville, AL 35807
Phone: (205) 971-8000
Fax: (205) 971-8699

© 1996 ADTRAN, Inc.
All rights reserved.
Printed in USA.

FEDERAL COMMUNICATIONS COMMISSION

RADIO FREQUENCY INTERFERENCE STATEMENT

This equipment has been tested and found to comply with the limits for a Class A digital device, pursuant to Part 15 of the FCC Rules. These limits are designed to provide reasonable protection against harmful interference when the equipment is operated in a commercial environment. This equipment generates, uses, and can radiate radio frequency energy and, if not installed and used in accordance with the instruction manual, may cause harmful interference to radio frequencies. Operation of this equipment in a residential area is likely to cause harmful interference in which case the user will be required to correct the interference at his own expense.

WARNING

Changes or modifications to this unit not expressly approved by the party responsible for compliance could void the user's authority to operate the equipment.

Table of Contents

Chapter 1. Introduction

Second Generation (2nd GEN) Nx56/64 V.35 Option Module Overview ..	1
2nd GEN Nx56/64 V.35 Plug-On Board Overview	1
Functional Description of the 2nd GEN Nx56/64 V.35 Option Module and Plug-On Board	2
Features of the 2nd GEN Nx56/64 Option Module	3
Interfaces	3
2nd GEN Nx56/64 (V.35) Option Module Specifications	4
Physical Description	5

Chapter 2. Installation

Unpack & Inspect	7
ADTRAN Shipments Include	7
Customer Provides	7
Installing The Option Module	8
Placement of the Option Module	8
Power Connection	8
Attaching the Plug-On Board	9
Warranty and Customer Service	10
Wiring	11
Power-Up Testing and Initialization	12

Chapter 3. Operation

Overview	13
Front Panel Indicators/Buttons	13
Menu Structure	13
2nd GEN Nx56/64 V.35 Menus Are All Submenus	14
Operation	14
2)PORT Status, Submenu of 1)Status	16
Operation	16
7)PORT CONFIG, Submenu of 2)CONFIG	17
Operation	17
3)FACTORY RESTORE, Submenu of 3)UTIL	21
Operation	21
7)PORT UTILITY, Submenu of 3)UTIL	21
Operation	21
2)RUN SELF TEST, Submenu of 4)TEST	22
3)PORT TEST, Submenu of 4)TEST	23
Operation	23

Appendix A. TSU/HSU X00 System Messages

Alarm Messages 25
 Network Interface (NI) 25
 2nd GEN Nx56/64 V.35 Option Module 25
Status Messages 26
 Network Interface (NI) 26
 2nd GEN Nx56/64 V.35 Option Module 26

List of Figures

Figure 1-1 2nd GEN Nx56/64 V.35 Option Module 5
Figure 2-1 Installing the Option Module 8
Figure 2-2 Attaching the Plug-on Board 9
Figure 3-1 TSU 100 Main Menu Tree 14
Figure 3-2 2nd GEN Nx56/64 V.35 Option Module Menu Tree 15
Figure 3-3 Port Status Submenu 16
Figure 3-4 Port Configuration Submenu 18
Figure 3-5 Inband Remote Configuration 20
Figure 3-6 Port Utility Submenu 21
Figure 3-7 Display of Port Name and Software Version 22
Figure 3-8 Port Test Submenu 23

List of Tables

Table 2-A V.35 Winchester Pin Connection 11
Table 3-A Normal Mode Operation (conditions which cause the
port control signal to be deactivated) 19

Chapter 1

Introduction

SECOND GENERATION (2ND GEN) NX56/64 V.35 OPTION MODULE OVERVIEW

The Second Generation (2nd GEN) Nx56/64 V.35 option module is one of the option modules available for use with the following ADTRAN equipment:

- TSU 100 (part number 1200052L1)
- TSU 600 (part number 1200076L1)
- TSU 120 (part number 1200129L1)
- HSU 100 (part number 1200097L1)
- HSU 600 (part number 1200098L1)

The 2nd GEN Nx56/64 V.35 option module installs in the option slot of the TSU/HSU family of products and provides an additional synchronous V.35 interface port. When used in these products, this interface port allows an additional DTE to have access to the T1 service.

2ND GEN NX56/64 V.35 PLUG-ON BOARD OVERVIEW

The operations of the 2nd GEN Nx56/64 V.35 option module described in this manual are also applicable for the 2nd GEN Nx56/64 V.35 plug-on board. Operation of both is identical except for the physical installation.

THE FUNCTIONAL DESCRIPTION OF THE 2ND GEN NX56/ 64 V.35 OPTION MODULE AND PLUG-ON BOARD

The 2nd GEN Nx56/64 V.35 option module operates in the option slot of the TSU/HSU products while the plug-on board operates as a *plug-on* to any option module. Both are under the control of the TSU/HSU product. The option module and the plug-on board are configured from the front panel or by an external PC program. The internal menus for their configuration are part of the option module and plug-on board and are automatically *installed* when either is plugged into a TSU/HSU product.

FEATURES OF THE 2ND GEN NX56/64 V.35 OPTION MODULE

- Operates using 1 to 24 DS0s
- Includes an elastic store for absorption of rate variations
- Capable of including a Nx56/64 V.35 plug-on interface port, resulting in a dual port module
- Outputs a 50 percent duty-cycle output clock at all rates
- Menu operation for easy configuration
- Executes and responds to V.54 looping codes
- Generates and checks a 511 test pattern
- Performs an extensive self test
- Supports multiport dial backup operation
- Provides inband channel network management communication

Interfaces

- CCITT V.35 electrical (differential)
- Connector
 - V.35 Winchester
- Loopbacks
 - Port (toward the network)
 - DTE (toward the DTE)Both loopbacks can be invoked locally or remotely (V.54)

2nd GEN Nx56/64 (V.35) Option Module Specifications

DTE Interface

CCITT V.35 Synchronous

Rates

56 kbps to 1.536 Mbps in 56K or 64K steps

Clock Options

Normal, Inverted

Tests

Local Loopback (Bilateral)

Menu activated

Remote Loopback (V.54)

Menu activated

Self Test

Test Pattern

511 with errored seconds display and error inject capability

Data Inversion

Menu selectable

1s Density Protection

Force 1s to network after one second of consecutive zeros from DTE. On/Off.

CTS, DCD, DSR Options

Normal or Forced ON

Connector

Winchester (V.35), female

Inband Communication Channel

Enabled, Disabled, or On-Demand

Physical Description

The 2nd GEN Nx56/64 V.35 option module plugs into the option slot in the rear of the TSU/HSU family of products (see Figure 1-1).

The rear panel of the option module includes a plastic plug over a cutout for a second V.35 connector. This allows a 2nd GEN Nx56/64 V.35 plug-on board (or any other plug-on board) to be added to the 2nd GEN Nx56/64 option module creating a multiport module. The PORT X.1 and X.2 indication is linked to the port numbering philosophy of the TSU/HSU product family. The X represents the slot number, into which the option module is plugged. For the TSU 100 there is only one option slot. Therefore the port designation would be 1.1 and, if a plug-on V.35 is present, port 1.2. In a TSU 600 with six option slots, these port numbers would be port 1.1 to port 6.1. The numbers appear in the front panel LCD menu displays.

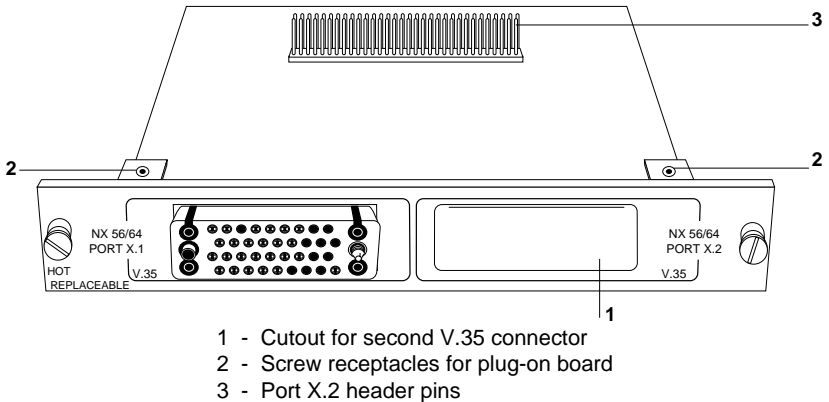

Figure 1-1
 2nd GEN Nx56/64 V.35 Option Module

Chapter 2

Installation

UNPACK & INSPECT

Carefully inspect the option module or plug-on board for any shipping damage. If damage is suspected, file a claim immediately with the carrier and then contact ADTRAN customer service. If possible, keep the original shipping container for use in shipping the option module or plug-on board back for repair or for verification of damage during shipment.

ADTRAN Shipments Include

- The 2nd GEN Nx56/64 Module or 2nd GEN Nx56/64 Plug-on Board
- The user manual (to be inserted into main TSU/HSU user manual)

Customer Provides

- DTE cable

INSTALLING THE OPTION MODULE

Placement of the Option Module

Figure 2-1 is representative of the action required for proper placement of the option module. Perform the following steps to install the option module:

1. Remove the cover plate from the TSU/HSU unit rear panel.
2. Slide the option module into the rear panel of the TSU/HSU unit until it is positioned firmly against the front of the unit.
3. Fasten the thumbscrews at both edges of the option module.

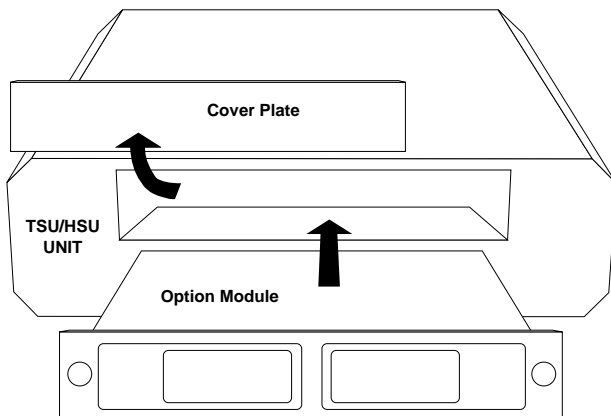

Figure 2-1
Installing the Option Module

Power Connection

Each option module derives power from the base TSU/HSU unit. Power to the TSU/HSU is supplied by a captive eight-foot power cord.

Attaching the Plug-On Board

Figure 2-2 is representative of the action required for proper attachment of a plug-on board to the option module. Perform the following steps to install the plug-on board:

1. Hold the plug-on board above the option module.
2. Using a downward and right-to-left motion, slip the V.35 Connector plug into opening in the option module back panel.
3. Moving the plug-on board downward, secure the connection of the header pins at the front of the boards.
4. Install the two 4-40 screws at both edges of the option module.

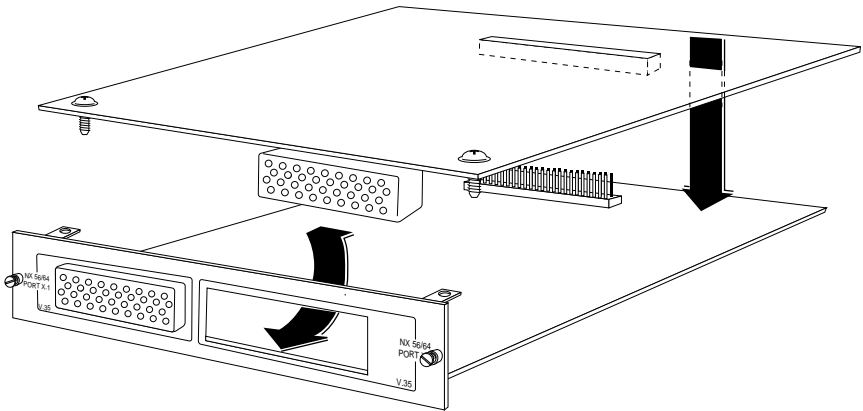

Figure 2-2
Attaching the Plug-On Board



The connection of the header pins between the option module and the plug-on board must be visually verified. Severe damage of the equipment can result from an improper connection.

WARRANTY AND CUSTOMER SERVICE

ADTRAN will replace or repair this product within five years from the date of shipment if it does not meet its published specifications or fails while in service. For detailed warranty, repair, and return information refer to the ADTRAN Equipment Warranty, Repair, and Return Policy Procedure.

Return Material Authorization (RMA) is required prior to returning equipment to ADTRAN.

For Service, RMA requests, or more information, contact one of the numbers listed at the end of this manual.

WIRING

The 2nd GEN Nx56/64 V.35 option module has a V.35 Winchester-style connection as defined in Table 2-A.

Table 2-A
V.35 Winchester Pin Connection

PIN	CCITT	DESCRIPTION
A	101	Protective ground (PG)
B	102	Signal ground (SG)
C	105	Request to send (RTS) from DTE
D	106	Clear to send (CTS) to DTE
E	107	Data set ready (DSR) to DTE
F	109	Received line signal detector (DCD) to DTE
H	-	Data terminal ready (DTR) from DTE*
J	-	Ring indicator (RI)*
L	-	Local loopback (LL) from DTE*
N	-	Remote loopback (RL) from DTE*
R	104	Received data (RD-A) to DTE
T	104	Received data (RD-B) to DTE
V	115	RX clock (RC-A) to DTE
X	115	RX clock (RC-B) to DTE
P	103	Transmitted data (TD-A) from DTE
S	103	Transmitted data (TD-B) from DTE
Y	114	TX clock (TC-A) to DTE
AA	114	TX clock (TC-B) to DTE
U	113	External TX clock (ETC-A) from DTE
W	113	External TX clock (ETC-B) from DTE
NN	-	Test mode (TM) to DTE

* Ignored by 2nd GEN Nx56/64 V.35 option module (firmware revision F or higher).

Power-Up Testing and Initialization

The option module executes a self test during the power-up sequence, as described in the TSU/HSU manual. No initialization input is required. Upon power-up, any previously configured setting for the option module is automatically restored.

When the self testing is completed and the configuration is successfully restored, the LED labeled OK in the MODULE group on the front panel turns *On*. For more information, see the section that discusses front panel operation in the *Operation* chapter of the appropriate TSU/HSU user manual. If any alarms are detected during operation, the red LED labeled ALARM in the MODULE group on the front panel turns *On*.

Chapter 3

Operation

OVERVIEW

The 2nd GEN Nx56/64 V.35 option module is controlled as part of the TSU/HSU using the same methods as described in the appropriate TSU/HSU user manual.

Front Panel Indicators/Buttons

Refer to the description of the TSU/HSU front panel indicators and buttons in the appropriate user manual.

Menu Structure

The 2nd GEN Nx56/64 V.35 option module menus appear as a subset of, and operate the same as, menus for the TSU/HSUs. The menus are accessed by selecting 1.1 2nd GEN Nx56/64 under the PORT menu items.

The Main menu for the TSU 100 is used for illustrative purposes. The Main menu for the other TSU/HSU units operates in a similar way. Figure 3-1 shows the TSU 100 Main menu with the PORT menu items printed in bold italics.

See the figure *TSU 100 Menu Tree* in the *TSU 100 User Manual* for a complete menu tree diagram.

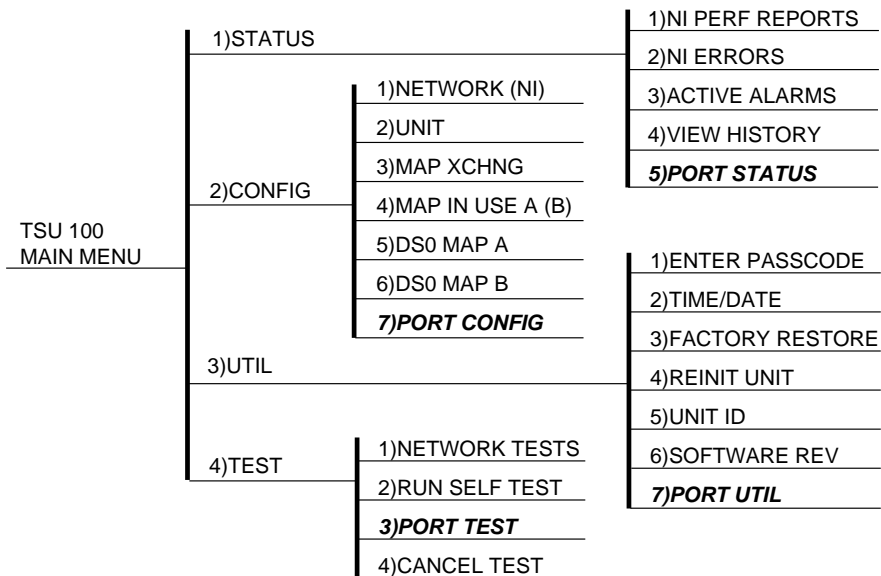

Figure 3-1
TSU 100 Main Menu Tree

2nd GEN Nx56/64 V.35 Menus Are All Submenus

The 2nd GEN Nx56/64 V.35 option module menus are accessed from and operated the same as menus for the TSU 100. Menu items in the Main menu in Figure 3-1 printed in *bold italics* are submenu choices for 2nd GEN Nx56/64 V.35 option modules (see Figure 3-2). Each submenu is discussed in the following paragraphs. All are accessed by the same method.

Operation

With the cursor on one of the four Main menu choices, press the **Enter** or number key. The results are a display of the first two submenu items with the cursor on the first item. Use the **Scroll Down** key to place the cursor on the desired item, then press **Enter**. This displays the first two submenu choices

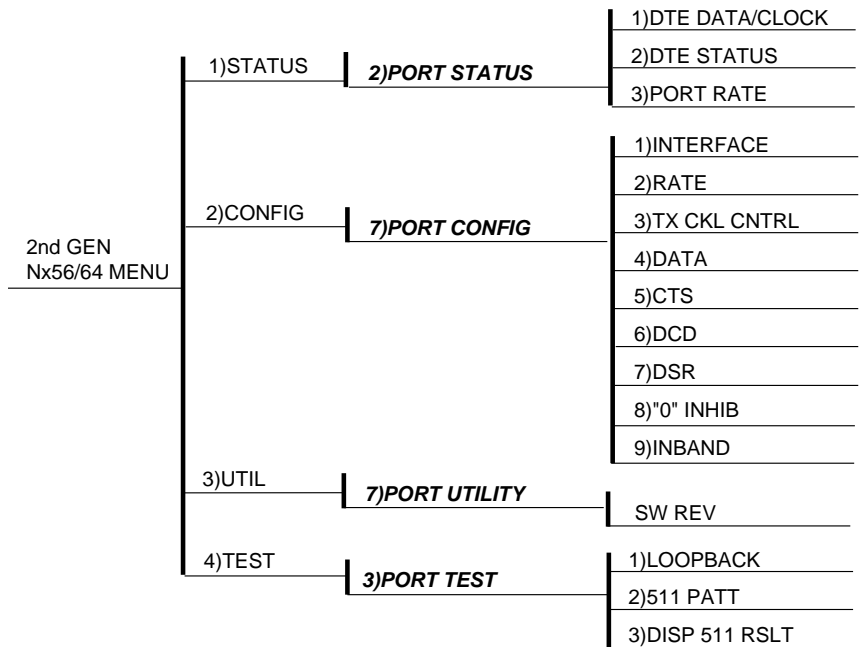

Figure 3-2
2nd GEN Nx56/64 V.35 Option Module Menu Tree

2)PORT Status, Submenu of 1)Status

The Status menu branch provides the ability to view the status of the TSU 100 operation. It displays the status of the monitored signal line on the 2nd GEN Nx56/64 V.35 option board and the data rate for which the option module is configured.

Operation

To display Figure 3-3 on the TSU 100, starting with the cursor on Main menu item 1)STATUS, do the following:

1. Press the **Enter** or the number **1** key. This displays the first two Status submenu items with the cursor on 1)NI PERF RPTS.
2. Use the **Scroll Down** key to place the cursor on 5) PORT STATUS and press the **Enter** key. This displays the first available port.
3. Use the **Scroll** keys to identify 1.1 2nd GEN Nx56/64 V.35 and press the **Enter** key.

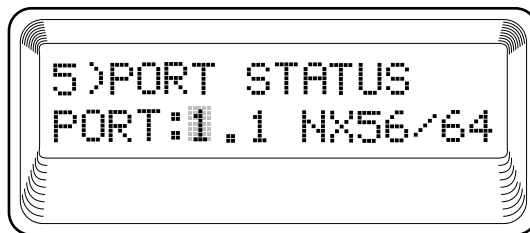

Figure 3-3
Port Status Submenu

The Nx interface offers the status screens listed in this manual. For other option modules, refer to the appropriate manual.

2ND GEN NX56/64 Status

Select 0.1 2ND GEN NX56/64

- 1) DTE DATA/CK
- 2) DTE STATUS
- 3) PORT RATE

DTE Data/CK

Shows the status (active or not active) of the following lines:

TXD	Transmit data from the DTE
RXD	Receive data toward the DTE
ETC	External transmit clock from DTE
LCK	Lock status of the phase locked loop

DTE Status

Shows the status (active or not active) of the following lines:

RTS	Request to send from DTE
CTS	Clear to send to DTE
DCD	Data carrier detect to DTE
DSR	Data set ready to DTE

Port Rate

Displays the data rate to which the NX port is set.

Exit the displays as described in the *TSU 100 User Manual*.

7)PORT CONFIG, Submenu of 2)CONFIG

The 7)PORT CONFIG submenu is used for configuration of the 2nd GEN Nx56/64 V.35 option module.

Operation

To display Figure 3-4 on the TSU 100, starting with the cursor on Main menu item 2)CONFIG, do the following:

1. Press the **Enter** or the number **2** key. This displays the first two Configuration submenu items with the cursor on 1)NETWORK (NI).
2. Use the Scroll Down key to place the cursor on 7)PORT CONFIG and press the **Enter** key.
3. Use the Scroll keys to identify 1.1 2nd GEN Nx56/64 V.35 option module. Only the bottom line of the display changes.



Figure 3-4
Port Configuration Submenu

To select Port Configuration, press the **Enter** key. This displays the first of eight submenu items. They are defined as follows:

1) INTERFACE

This selects the active interface for the Base Nx port. The Nx ports, which are installed as option modules, have only one type of interface.

Choice - V.35

2) RATE 56/64

This sets the base rate of the interface. The actual data rate depends on the number of DS0s assigned to the Nx port. The DTE data rate versus the number of DS0s appear in the appendix *DTE Data Rate Chart* of the *TSU 100 User Manual*.

Choices - 56K or 64K

3) TX CLK

Controls the clock used by the TSU 100 to accept the transmit (TX) data from the DTE. Normally this is set to Normal. If the interface cable is long, causing a phase shift in the data, the clock can be selected as Inverted. This switches the phase of the clock which should compensate for a long cable.

Choices - Normal or Inverted

4) DATA

Used to control the inverting of the DTE data. This inversion can be useful when operating with a high-level data link control (HDLC) protocol (often used as a means to ensure 1s density).

Choices - Normal or Invert

5)CTS

Used to control characteristics of CTS.

Choices - Normal or Force On (see Table 3-A).

6)DCD

Data Carrier Detect - Indicates to the DTE when a valid signal is being received at the Network Interface.

Choices - Normal or Force On (see Table 3-A).

7)DSR

Data Set Ready - This signal indicates to the DTE when the DCE is turned *On* and ready for operation.

Choices - Normal or Force On (see Table 3-A).

8)O INHIB

If the Nx interface detects an uninterrupted string of 0s being transmitted toward the network, and if 0s are transmitted for more than one second, then the TSU 100 forces 1s towards the network.

Choices - On or Off

Table 3-A

Normal Mode Operation

(conditions which cause the port control signal to be deactivated)

SIGNAL	RTS	V.54 LOOPBACK	511 TEST ON	SELF TEST ACTIVE	NETWORK TEST ACTIVE	NO DSO MAPPED	NETWORK ALARM
CTS	Follows	Off	Off	Off	Off	Off	Off
DCD	-	-	-	Off	Off	Off	Off
DSR	-	Off	Off	Off	Off	Off	-
- = Do not care Force On = On under all conditions							

9)INBAND (Inband Configuration Channel)

Used to enable/disable an 8 kbps remote configuration channel (see Figure 3-5). When this option is set to ON, the first DS0 mapped to the Nx interface operates in 56K mode and the DTE clock rate is reduced by 8 kbps. The TSU/HSU uses this 8 kbps channel to send and receive configuration data across a T1 span. As shown in Figure 3-5, this allows the PC connected to the chain-in port on TSU 600 A to monitor/configure both TSU 600 A and B. This feature is useful when FDL connectivity is not available across the T1 span.

This 8 kbps channel is only taken out of the first DS0. If two 64K DS0s are mapped, the DTE rate would be 120 kbps instead of 128 kbps.

The menu option can also be set to On-Demand which will activate the Inband Channel only when commands are sent from T-Watch to the remote unit (TSU 600 B in Figure 3-5). If no T-Watch activity is detected for 10 minutes, the Inband Channel is deactivated.

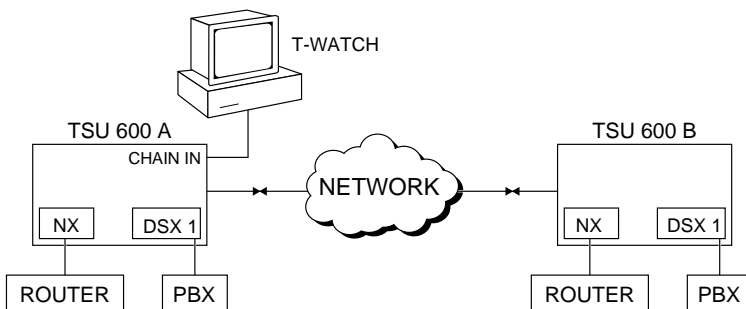

Figure 3-5
Inband Remote Configuration



Although a router can accommodate this 8K rate reduction, some DTE devices may not (i.e., video). Determination should be made if the connected DTE can handle this reduced clock source. A second option would be to operate in 56K/DS0.

3)FACTORY RESTORE, Submenu of 3)UTIL

This selection is used to restore the factory default settings for all Passthru option module parameters.

Operation

To return the unit to the opening Main menu with all the factory default settings restored, do the following:

1. Follow the standard operating procedure to access the 3)UTIL menu items.
2. With the cursor on 3)FACT RESTORE, press the **Enter** key.

7)PORT UTILITY, Submenu of 3)UTIL

The 7)PORT UTILITY submenu is used primarily to display the current software information for each port installed in the unit. This information is required when requesting assistance from ADTRAN Technical Support or when updates are needed.

Operation

To display Figure 3-6 on the TSU 100, do the following:

1. Follow the standard operating procedure to access the 3)UTIL menu items.
2. With the cursor on 7)PORT UTILITY, press the **Enter** key. This displays the first available port.

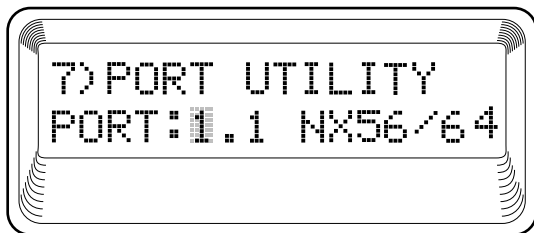

Figure 3-6
Port Utility Submenu

To display the port name and the software version installed as shown in Figure 3-7, do the following:

1. Use the **Scroll** keys to move through the available ports, or enter the port number with the number key.
2. When the desired port name is displayed, press the **Enter** key.

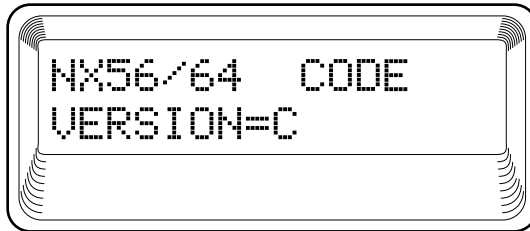

Figure 3-7
Display of Port Name and Software Version

Press the **Cancel** key to exit or to select another port.

2)RUN SELF TEST, Submenu of 4)TEST

This menu item is used to execute both the internal test of the TSU/HSU and of the 2nd GEN Nx56/64. This is the same test executed during power-up. The results of the self test are shown on the TSU 100 display. For additional information on self test, see the chapter *Operation* in the appropriate TSU/HSU user manual.

To activate a self test, do the following:

1. Follow the standard operating procedure to access the 4)TEST menu items.
2. With the cursor on 2)RUN SELFTEST, press the **Enter** key. This results in a changing TSU/HSU display, showing the test outcome.

3)PORT TEST, Submenu of 4)TEST

This menu item is used to activate testing of specific data ports. It also controls the activation of loopbacks and the initiation of data test patterns. Test results are shown on the TSU/HSU display.



NOTE

The execution of Port Tests disrupts normal data flow in the port being tested.

Operation

To display Figure 3-8 on the TSU 100, starting with the cursor on 3)PORT TEST, press the **Enter** or number **3** key. This displays the available ports.

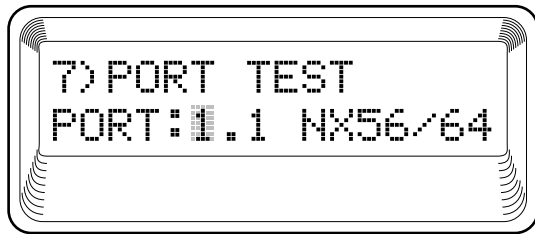

Figure 3-8
Port Test Submenu

1.1 2nd GEN Nx56/64: The Nx interface offers the following test functions:

1) LOOPBK

Initiates a loopback.

- | | |
|---------|--|
| PRT/LCL | The Nx port activates both a local loopback (back toward the DTE) and a port loopback when either is invoked. |
| REMOTE | The remote loopback causes a V.54 code to be sent to the far end. The Nx at the far end activates a PORT/LCL loopback on detection of the V.54 code. |
| OFF | The loop is deactivated. |



The TSU/HSU checks the remote loopback activation by detecting a proper response from the remote end. While waiting for the response, the display shows LOOPING. If successful, the display changes to LOOPED UP. If unsuccessful, the display shows FAILED.

2)511 PATT

Activates the generation of the 511 test pattern.

- ON The pattern check circuitry is enabled and a test started. The test is ended by selecting OFF.
- OFF The pattern generation and check is disabled.

3)DIS 511 RESULT

Displays the results of the 511 test indicated in 2)511 PATT. The results are in the form of the number of errored seconds. The error count can be cleared by pressing the Clear key (**Shift + 9**). A bit error may be inserted into the data stream by pressing the 2 key.

Appendix A

TSU/HSU X00 System Messages

ALARM MESSAGES

Network Interface (NI)

Red Alarm

NI unable to align frame with incoming signal

Yellow Alarm

Remote alarm indication (RAI) being received from the far end

Blue Alarm

Unframed all 1s (AIS) being received at NI

Loss of Signal

No signal detected at NI

2nd GEN Nx56/64 V.35 Option Module

Clock Slip

Difference in frequency of the data clock at the network and DTE

PLL Alarm

Unable to lock phase lock on the clock provided by the network interface

Zeros Alarm

All 0s data being sent to the network interface

No EXT Clock

No external transmit clock at DTE (when applicable)

STATUS MESSAGES

Network Interface (NI)

Payload On

Payload loopback activated

Line On

Line loopback activated

Loopback Off

All loopbacks deactivated

Factory Restore

Factory setting restored

Power On

Unit powered on

Self Test

Internal self test performed

2nd GEN Nx56/64 V.35 Option Module

Loop Up

Data is looped back at both the network interface and the DTE interface of the card

Remote Loop Up

Sending a V.54 pattern in an attempt to loop up a remote device

511 Pattern On

Sending a 511 pattern towards the network interface

Loop Down

Data is no longer looped back at the network interface or the DTE interface

511 Pattern Off

No longer sending a 511 pattern towards the network interface

Product Support Information

Pre-Sales Inquiries and Applications Support

Please contact your local distributor, ADTRAN Applications Engineering, or ADTRAN Sales:

Applications Engineering (800) 615-1176
Sales (800) 827-0807

Post-Sale Support

Please contact your local distributor first. If your local distributor cannot help, please contact ADTRAN Technical Support and have the unit serial number available.

Technical Support (800) 726-8663

Repair and Return

If ADTRAN Technical Support determines that a repair is needed, Technical Support will coordinate with the Return Material Authorization (RMA) department to issue an RMA number. For information regarding equipment currently in house or possible fees associated with repair, contact RMA directly at the following number:

RMA Department (205) 971-8722

Identify the RMA number clearly on the package (below address), and return to the following address:

ADTRAN, Inc.
RMA Department
901 Explorer Boulevard
Huntsville, Alabama 35806-2807

RMA # _____

